

**Modular Cooking Range Line  
 thermaline 80 - 600mm Passth. Electric  
 Warming Cabinet, 2 doors, GN conform,  
 2 Sides(H2)-H=450**

ITEM # \_\_\_\_\_

MODEL # \_\_\_\_\_

NAME # \_\_\_\_\_

SIS # \_\_\_\_\_

AIA # \_\_\_\_\_



**588310 (MA4JCCFOAO)**

Passthrough electric  
 Warming Cabinet, with 2  
 doors, two-side operated,  
 GN - H2

### Short Form Specification

**Item No.** \_\_\_\_\_

600 mm wide passthrough warming cabinet with 2 doors. Internal frame for heavy duty sturdiness in stainless steel. Flat surface construction, easily cleanable. Temperature in the cabinet can be set through thermostat, up to a maximum of 110 ° C. Cabinet storage space accepts GN 1/1 containers. IPX5 water resistant certification. Configuration: Two-side operated freestanding base, hygienic class H2.

### Main Features

- All major components may be easily accessed from the front.
- THERMODUL connection system creates a seamless work top when units are connected to each other thus avoiding soil penetrating vital components and facilitating the removal of units in case of replacement or service.
- Unit constructed according to DIN 18860\_2 with 70 mm recessed plinth.
- Temperature in the cupboard can be set through a thermostat to suit different requirements. The maximum temperature is 110°C.
- Unit can be installed below modular top appliances, designed to keep plates warm.

### Construction

- IPX5 water resistance certification.
- 2 mm top in 1.4301 (AISI 304).
- Flat surface construction with minimal hidden areas to easily clean all surfaces
- Storage space in the base of the appliance accepts GN1/1 containers.
- Internal frame for heavy duty sturdiness in stainless steel.

**APPROVAL:** \_\_\_\_\_

Front

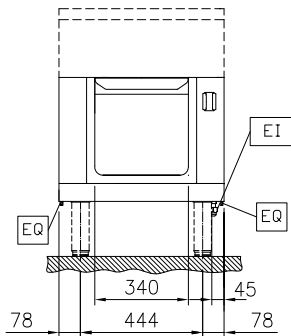

Side

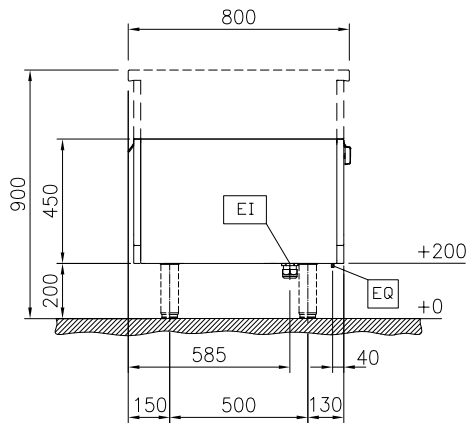

EI = Electrical inlet (power)

Top

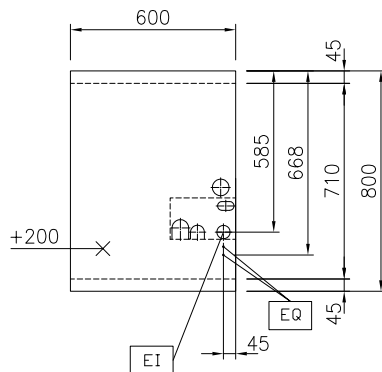
**Key Information:**

External dimensions, Width:	
588310 (MA4JCCFOAO)	600 mm
External dimensions, Depth:	800 mm
External dimensions, Height:	450 mm
Cupboard Cavity Dimensions (width):	340 mm
Cupboard Cavity Dimensions (height):	330 mm
Cupboard Cavity Dimensions (depth):	710 mm
Cabinet temperature range:	30-110 °C
Net weight:	26 kg

**Sustainability**

Current consumption:	2.5 Amps
----------------------	----------

## Optional Accessories

- Stainless steel side panel, 800x700mm, freestanding PNC 912509
- Stainless steel front kicking strip, 600mm width PNC 912632
- Stainless steel side kicking strip left and right, freestanding, 800mm width PNC 912655
- Stainless steel plinth, freestanding, 600mm width PNC 912861
- Perforated shelf for warming cabinets and cupboard bases (one-side operated TL80-85-90 and two-side operated for TL80) PNC 913233
- Energy optimizer kit 14A - factory fitted PNC 913244
- Side reinforced panel only in combination with side shelf, for freestanding units PNC 913258
- Shelf fixation for TL80-85-90 one-side operated, TL80 two-side operated PNC 913279
- Stainless steel dividing panel, 800x700mm, (it should only be used between Electrolux Professional thermaline Modular 80 and thermaline C80) PNC 913668
- Stainless steel side panel, 800x700mm, flush-fitting (it should only be used against the wall, against a niche and in between Electrolux Professional thermaline and ProThermetic appliances and external appliances - provided that these have at least the same dimensions) PNC 913684